LuxCSD Operational Arrangements for Issuers and Agents

December 2023

Document number: 6578

This document is the property of LuxCSD, société anonyme ("LuxCSD"). No part of this document may be reproduced or transmitted in any form or by any means, electronic or mechanical, including photocopying and recording, for any purpose without the express written consent of LuxCSD. Information in this document is subject to change without notice and does not represent a commitment on the part of LuxCSD.

© Copyright LuxCSD. All rights reserved.

Contents

1. Introduction

1.1	Purpose of the Operational Arrangements	1
1.2	Timing conventions	1
1.3	Communication means and formats	1
1.4	Amendments to the Operational Arrangements	1
1.5	Governance	1

2. General information

2.1	Issuers and agents	3
2.2	Qualifying Securities	4
2.3	Security documentation	5
2.4	Preannouncement date and confidential information	7
2.5	Specific security characteristics	7
2.6	Investigations	8
2.7	Messaging	8

3. Accounting

3.1	For Qualifying Securities in bearer form (LBN)	9
3.2	For Qualifying Securities in registered form (LRN)	9
3.3	For Qualifying Securities in dematerialised form (LDN)	9

4. Issuance

4.1	Issuance models	11
4.2	Security identification	12
4.3	LuxCSD eligibility assessment	12
4.4	Closing activities	13
4.5	Primary market distribution	14
4.6	Payment	15
4.7	Fungibility of tranches	15
4.8	Summary of issuance timings	16

5. Asset servicing

5.1	Corporate action events	17
5.2	Meeting notifications and proxy voting	20
5.3	Shareholder Rights Directive (SRD) II specific provisions	21
5.4	Exchange GT to GP and fungibility	22
5.5	Disposal process	23
5.6	Tax information and processing	24
5.7	Record keeping	24
5.8	Reconciliation	25
5.9	Reconciliation reporting	28

6. Performance monitoring

7. Business continuity and disaster recovery

Appendix 1. Swift messages summary	35
------------------------------------	----

Appendix 2. Contact list	43
--------------------------	----

Appendix 3. Reconciliation discrepancy template	45
Appendix 4. Data Protection	47
Appendix 5. Communications formats for Corporate Actions under the Shareholder Rights Directive II	49
Appendix 6. Signature Page	51
Glossary	53

Figures

Figure 2-1.	Contractual framework	3
Figure 4-1.	Issuance	11
Figure 4-2.	Issuance Models	11
Figure 4-3.	DVP Syndication Issuance (Model 1) Flow	15
Figure 4-4.	Summary of DVP issuance timings	16
Figure 5-1.	Asset Servicing events	17
Figure 5-2.	Securities End of Life	23
Figure 5-3.	Reconciliation	25

1. Introduction

1.1 Purpose of the Operational Arrangements

The purpose of the Operational Arrangements is to provide Issuers and their appointed Agents with LuxCSD contractual and operational requirements for an issue to become and remain eligible for LuxCSD services. They are an integral part of the contractual agreement between LuxCSD and the agents. All agents of LuxCSD eligible equity and debt securities shall comply with the requirements set forth in the Operational Arrangements.

The Operational Arrangements focuses on common processing flows and should be used as a framework for other processing flows that may be required. By following the recommendations and standards contained within these Operational Arrangements, Issuers and their Agents shall, to a large extent, ensure an efficient and effective end-to-end service to investors.

The content of the LuxCSD Operational Arrangements does not apply to investment funds (bearer, register or dematerialised form) under the CFF structure.

Additional publications relating to the operational aspects of LuxCSD are available on the LuxCSD website (www.luxcsd.com).

1.2 Timing conventions

Unless otherwise stated, all deadlines and timings throughout this document are expressed in a HH:MM 24-hour-per-day format and in Central European Time (CET).

1.3 Communication means and formats

All communication between Agents and LuxCSD, including, without limitation, any type of notification, pre-advice, instruction, or confirmation, shall be performed using the communication means defined in the LuxCSD Swift Guide for Agents.

1.4 Amendments to the Operational Arrangements

The Operational Arrangements may be amended at the discretion of LuxCSD in accordance with the provisions of the Agent-LuxCSD Agreement.

1.5 Governance

The issuer community shall have access to the Issuer Advisory Group that meets regularly with LuxCSD to discuss the market needs and to align these needs against the services LuxCSD provides.

1. Introduction

This page has intentionally been left blank.

2. General information

2.1 Issuers and agents

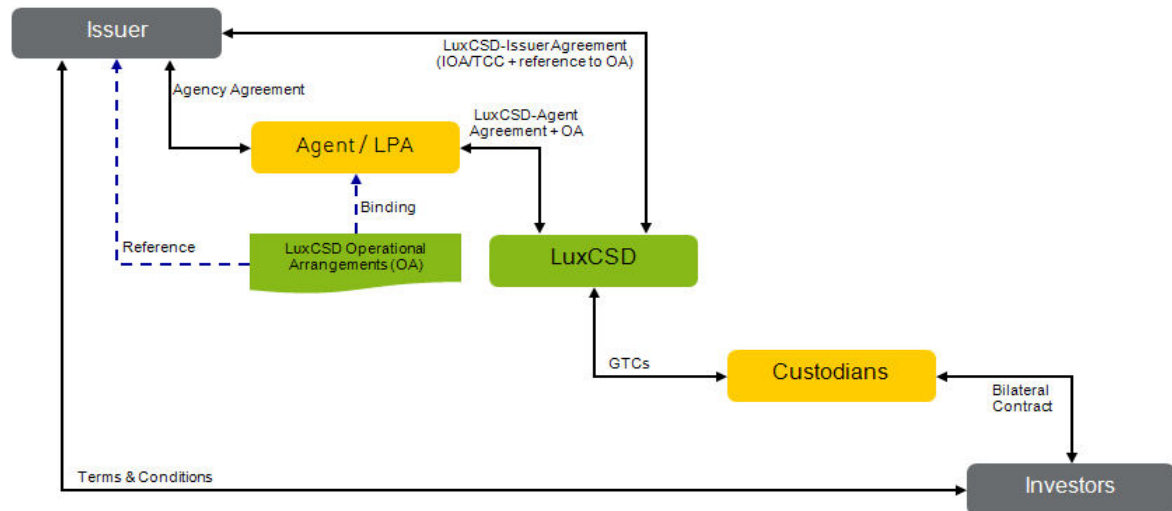

Figure 2-1. Contractual framework

Agents shall be required to comply with the Operational Arrangements and any additional requirements depending on their role. An overview of the contractual framework is provided above in "[Contractual framework](#)".

- Issuer

The Issuer is required to sign the LuxCSD-Issuer Agreement for its securities to be eligible for issuance and settlement in LuxCSD. This Agreement will govern the relationship between the two parties regarding the maintenance and reconciliation of the issued outstanding amount (IOA) for Qualifying Securities of the Issuer and will also serve to appoint LuxCSD as Organisme de Liquidation (OL), where applicable.

The Issuer may assign Agents to perform the day to day activities for issuance, and asset servicing of the Qualifying Securities.

- LuxCSD Principal Agent (LPA)

The LPA is appointed by the Issuer to ensure compliance with the LuxCSD operational requirements, as described in this document. The appointment of an LPA is required for eligibility of a security in LuxCSD. The primary responsibilities of the LPA are to provide standard communications (ISO/SMPG standards) and assistance to LuxCSD ensuring timely and accurate processing of LuxCSD securities. The LPA is also responsible for the verification of issuer's signatures. Institutions are required to sign the LuxCSD-Agent Agreement to be recognised by LuxCSD as qualified LPA. The list of qualified LPAs shall be made available by LuxCSD on its website.

The name of the appointed LPA shall be mentioned in the Terms and Conditions of the Qualifying Securities. Any change of LPA during the life of a Qualifying Security shall be communicated by the new LPA at least five business days before the effective change date.

2. General information

LuxCSD shall inform the relevant LPA and Issuers if and when an institution is removed from the list of eligible LPAs.

- Other Agents (Issuing and Paying Agent, Principal Paying Agent, Conversion Agent, Calculation Agent, Determination Agent, Fiscal Agent etc.).

LuxCSD may, wherever described in this document or at their discretion, interact directly with the relevant Agent(s) for the purpose of improving the investors' market deadlines (for example delivering investor choices for a corporate action event).

2.2 Qualifying Securities

All documentation and information requirements of Qualifying Securities shall be provided to LuxCSD in English. Qualifying Securities and the security denomination shall be in one of the LuxCSD eligible denomination currencies. A list of eligible denomination currencies can be found on the LuxCSD website. Registered securities must be recorded under the name of LuxCSD.

Forms of securities

Qualifying Securities are securities which may be represented by any of the following forms:

- Materialised form (immobilised for settlement in book entry)
 - Bearer instruments: represented by a global certificate that refers to the records of the LuxCSD for evidence of the total IOA of the issuer.
 - Registered instruments: represented by a global certificate that shall be registered in the name of LuxCSD in the books of the registrar.

Qualifying Securities in materialised form can be represented by the following types of global certificates:

- Temporary global (GT): global certificate issued for the period between the closing and the effective exchange for either a permanent global certificate or for definitive certificates in the denominations foreseen in the Terms and Conditions of such issue. The exchange of securities from global form into definitive form is total and irreversible.
- Permanent global (GP): global certificate representing the security until it is matured or terminated (for example early reimbursement). A permanent global certificate is normally not exchanged into securities in definitive form unless under limited circumstances as described in the Terms and Conditions of such issue.

Securities in semi-permanent global form or in definitive form are not accepted by LuxCSD.

- Dematerialised form
 - Dematerialised instruments: represented by book entries in LuxCSD and recorded as such in the issuance account in the books of LuxCSD where LuxCSD has been appointed as Organisme de Liquidation (OL) by the Issuer.

Types of securities

Bearer and Registered Qualifying Securities:

- Debt instruments: money market instruments (for example CP, CD, MTNs), bonds, convertibles, asset-backed securities etc.;
- Equity instruments: warrants, ordinary shares, preferred shares etc.;
- Structured products.

Dematerialised Qualifying Securities:

- Equity securities (for example shares, founders' shares, subscription rights or units of UCI) issued by Luxembourg public companies; and
- Debt securities governed by Luxembourg law, as well as by any other law for which LuxCSD has received regulatory authorisation in accordance with Article 23 CSDR.

The content of the Operational Arrangements does not apply to investment funds under the CFF structure.

2.3 Security documentation

LuxCSD requires that the security documentation is provided in English and in a timely manner allowing LuxCSD to assess the securities eligibility, and asset servicing requirements. The type of documentation required depends on the security¹:

- For under programme: Base Prospectus, Final Terms. These are normally provided by the Issuer Agent.
- For Stand-alone: Prospectus, Terms & Conditions. These are normally provided by the Lead Manager.

Draft documentation

Draft documentation is used in advance of the final documentation to provide an ISIN code and LuxCSD eligibility assessment. Draft documentation should include the minimum requirements as per ISMAG Stand Alone security acceptance and eligibility checklist or Programme Acceptance checklist to ensure the use of standard terms and formats to allow accurate and easy evaluation and understanding of securities information².

Draft documentation shall be provided as soon as available, and at least five business days before closing date. Draft documentation must be sent to newissuesluxcsd@luxcsd.com.

Final documentation

The final eligibility acceptance shall only be given on the basis of the final documentation.

Final documentation shall be provided at the latest on closing date. Final security documentation provided to LuxCSD should follow the Naming Convention as defined by the ISMAG New Issues Working Group (www.clearstream.com/ismag)³. LuxCSD recommends that final documentation is provided via SwiftNet FileAct to ensure the issuance of the securities without undue delay.

1. List is not exhaustive. The final documentation requirement depends on the type of security being issued.

2. Security issuance checklists cover programme and stand-alone issuance and are available from www.luxcsd.com.

3. The International Securities Market Advisory Group (ISMAG) is a major efficiency programme created to harmonise issuance and asset servicing processes of international securities primarily deposited in the International Central Securities Depositories (ICSDs).

2. General information

Documentation required for Luxembourg law dematerialised securities

For the purpose of the draft documentation, should include the minimum requirements as per ISMAG Stand Alone security acceptance and eligibility checklist or Programme Acceptance checklist to ensure the use of standard terms and formats to allow accurate and easy evaluation and understanding of securities information. Security issuance checklists cover programme and stand-alone issuance, and are available from www.luxcsd.com. Issuance of dematerialised securities in accordance with the law of 6 April 2013 on the dematerialised securities (the “**Dematerialisation Law**”), LuxCSD requires that the following documentation shall be provided at least 10 business days prior to the issuance date allowing LuxCSD to review and assess the securities eligibility and perform its obligations under the Dematerialisation Law:

For the purpose of the present section of the Operational Arrangements, the terms securities shall be understood within the meaning of the article 1 (11) of the Dematerialisation Law and shall cover equities and debt instruments.

For the creation of securities

For **newly incorporated issuer**:

- Articles of association or the management regulation of the Issuer (as the case may be) certified by the notary providing for the issuance of securities in dematerialised form;
- Issuer’s agreement or any decision of the competent corporate body of the Issuer appointing LuxCSD as the sole settlement organisation (*Organisme de liquidation*);
- Disclose in a national newspaper and on its website, if available, the name and address of LuxCSD as the appointed settlement organisation.
- If available, an updated excerpt of the trade and companies register disclosing the name and address of LuxCSD as the appointed settlement organisation

For **existing issuer and issuance of new shares under dematerialised form**:

- The updated version of the articles of association certified by the notary, or the management regulation of the Issuer (as the case may be) providing expressly for (1) the Issuer’s ability to issue dematerialised securities; (2) the types of securities issued in dematerialised securities.
- For the capital increase within the limit of the authorised share capital, LuxCSD may require the decision of the competent corporate body certified by the notary or a copy of the notarial deed related to such capital increase;
- Issuer’s agreement or any decision of the competent corporate body of the Issuer appointing LuxCSD as the sole settlement organisation (*Organisme de liquidation*);
- An updated excerpt of the trade and companies register disclosing the name and address of LuxCSD as the appointed settlement organisation;
- Disclose in a national newspaper and on its website, if available, the name and address of LuxCSD as the appointed settlement organisation.

In the case of issuance of shares under the authorised capital (for example, option exercise, warrant exercise), the following documents are required:

- In a timely manner (latest on issuance date -1):
 - Board resolution (indicating whether or not all conditions for the issuance of the shares have been fulfilled);
 - MU instruction with authorised signatures.
- Notarial deed: Latest within one month from the end of the subscription period or within three months from the day on which that period commenced (Article 420-23 Law of 10 August 1915).

If the board resolution states that not all conditions for the issuance of the shares have been fulfilled, the notarial deed is required latest early morning on issuance date.

For capital increase of Luxembourg law *société anonymes* and issuance of securities within the limit of the authorised share capital, the disclosure in a national newspaper and on its website, if available, the name and address of LuxCSD as the appointed settlement organisation is not required.

For the conversion of securities

- The updated version of the articles of association certified by the notary or the management regulation of the Issuer (as the case may be) providing expressly for (1) the Issuer's ability to issue dematerialised securities; (2) the securities to be converted in dematerialised securities; (3) the mandatory or optional characteristic of the conversion; (4) the conversion procedure; (5) if the conversion is mandatory, the time limit for the conversion and the sanctions in case the securities are not presented for dematerialisation within this time limit. The time limit for the conversion shall be at least 2 years;
- Issuer's agreement or any decision of the competent management corporate body of the Issuer appointing LuxCSD as the sole settlement organisation (Organisme de liquidation);
- disclose in a national newspaper and on its website, if available, the name and address of LuxCSD as the appointed settlement organisation;
if available, an updated excerpt of the trade and companies register disclosing the name and address of LuxCSD as the appointed settlement organisation.

Final documentation updates

When final security documentation has been updated (for example, due to a manifest error), LuxCSD requires the new security documentation on the day of the update.

2.4 Preannouncement date and confidential information

Information to holders of securities (communications, upcoming corporate event details, notices, resolutions made etc.) shall be provided to LuxCSD on a confidential basis as early as possible and before being provided to the holders to ensure sufficient time between the availability of information to LuxCSD and its dissemination to the holders. The Agent shall send the communication, including the official announcement date to investors, to LuxCSD.

LuxCSD shall release the information to clients on the official announcement date. If requested to do so, LuxCSD shall sign a confidentiality or a non-disclosure agreement.

2.5 Specific security characteristics

The purpose of this section is to define the expectations related to some security characteristics required for the efficient processing of Qualifying Securities. This section covers the following items:

- Non-standard structures;
- Day Count convention;
- Paperless instructions;
- Units/Nominal;
- Record date.

Non-standard structures

Any non-standard structure shall be notified to LuxCSD New Issues by the IA/LM for eligibility review before requesting an ISIN or Programme number.

2. General information

Day count convention

LuxCSD recommends the use of the day count conventions as published in the ISMAG Market Practice Book (www.clearstream.com/ismag). Where justification exists for use of an alternative day count convention, the documentation shall refer to the relevant day count standard being used.

Paperless instructions

To facilitate a paperless processing environment, LuxCSD Qualifying Securities require use of standard wording in the issue's Terms and Conditions to support the use of electronic forms and communication means.

Where local jurisdiction requires paper instructions, this information must be highlighted to LuxCSD for eligibility assessment.

Units/Nominal

The Terms and Conditions shall clearly indicate whether Units or Nominal is being used, and identified in the related fields in the Security issuance checklists.

Record date

For LuxCSD Qualifying Securities the Record date shall be defined as "close of the business day prior to the Entitlement Date"¹.

2.6 Investigations

Whenever queries are raised by LuxCSD the following priorities and timing shall be expected from the Issuer and Agents:

- High: resolution expected within four hours;
- Medium: resolution expected within one business day;
- Low: resolution expected within two business days.

2.7 Messaging

See the LuxCSD Swift Guide for Agents for the format and content of information to be provided.

1. ICMSA Recommendation on Record Dates

- **DO NOT**, as issuer of bearer securities,
 - include definitions referring to a record date, or
 - create provisions within the governing documentation referring to a snap shot date different from Payment Date -1 Business Day;
- **DO**, for all instruments in global registered form with Closing Dates after 1 January 2010 word legal documentation with a record date as at the "close of the Business Day prior to the **Entitlement Date**".

3. Accounting

The need for marking up or down the Issue Outstanding Amount (IOA) of Qualifying Securities may result from various events during the securities term.

3.1 For Qualifying Securities in bearer form (LBN)

LuxCSD shall maintain the IOA in its books and records on behalf of the issuers and shall therefore mark this amount up and down in accordance with instructions received from the issuer via the LuxCSD Principal Agent (LPA) in line with events occurring throughout the security term.

LuxCSD shall not make any physical annotation to the global certificate.

3.2 For Qualifying Securities in registered form (LRN)

The IOA shall be maintained by an Agent (the registrar) appointed by the Issuer. The amount of securities issued in LuxCSD shall be recorded in the register under the name of LuxCSD and evidenced as such on the corresponding global certificate.

In the case of a change in the IOA, the Issuer shall arrange for delivery of the new global certificate to LuxCSD and the LPA shall provide LuxCSD with the MD/MU confirmation received from the registrar (see "[Issuance](#)" on page 11).

LuxCSD shall not update its records before having received (1) an updated global certificate and (2) the LPA confirmation, with the exception of the processing of fungibility.

3.3 For Qualifying Securities in dematerialised form (LDN)

In the case where LuxCSD is appointed as the OL by the issuer, LuxCSD shall maintain the compte d'émission on behalf of the Issuers and the mark up/down process shall reflect the procedure described in "[For Qualifying Securities in bearer form \(LBN\)](#)".

3. Accounting

This page has intentionally been left blank.

4. Issuance

LuxCSD offers a range of issuance services both as Issuer CSD and as Investor CSD. These services include customised support to the issuing community to assist the market in becoming more efficient and in reducing risk.



Figure 4-1. Issuance

4.1 Issuance models

Syndicated



Non-Syndicated



Figure 4-2. Issuance Models

LuxCSD as Issuer CSD allows three issuance models:

- Model 1 - A syndication model where the issuance takes place in LuxCSD between the Issuer (Agent) and Lead Manager accounts with subsequent distribution between Lead Manager and Allottees. The initial credit of securities is made on the Issuer (Agent) issuance account.
- Model 2 - The traditional syndication model used in the international markets, where the Lead Manager settles against allottees and manage payment to issuers outside LuxCSD. The initial credit of securities is made on the Lead Manager issuance account.
- Model 3 - The traditional non-syndicated model used in the international markets, where the Issuer (Agent) settles against the dealer or investor. The initial distribution is performed directly with the dealer. The initial credit of securities is made on the Issuer (Agent) issuance account.

4. Issuance

4.2 Security identification

For Qualifying Securities, Issuers and Agents shall first approach the competent national numbering agency (NNA), to obtain the ISIN in accordance with ISO 6166. LU ISIN requests may be submitted to LuxCSD who then obtains the ISIN from Clearstream Banking S.A., acting as the Luxembourg NNA.

4.3 LuxCSD eligibility assessment

Issuers and Agents shall request security eligibility at LuxCSD by submitting the official issuance/ programme documentation and the appropriate contractual agreements¹. LuxCSD shall review the terms of the issuance against its own eligibility criteria.

Issuers and Agents shall ensure that the Final Terms or similar official issuance documentation is provided to LuxCSD at the latest on Closing Date of the security or execution date of the programme. Draft documents however may be used to support eligibility requests.

For Qualifying LBN Securities, the legend on the certificate shall bear the following text:

“The nominal amount of Notes represented by this Global Note shall be the total amount from time to time entered in the records of LuxCSD. The records of LuxCSD shall be conclusive evidence of the nominal amount of Notes represented by this Global Note and, for these purposes, a statement issued by LuxCSD (which statement shall be made available to the bearer upon request) stating the nominal amount of Notes represented by this Global Note at any time shall be conclusive evidence of the records of LuxCSD at that time.”

LuxCSD reserves the right to remove eligibility status from securities for which no final issuance documentation has been timely received. Likewise, any modification to the terms of a Qualifying Security or eligible programme must be immediately notified to LuxCSD by the issuer or its agents, and updated documentation must be provided as soon as it becomes available.

Under programme

LuxCSD processes the acceptance of a new qualifying programme after receipt of the official issuance documentation.

Upon acceptance of a programme, LuxCSD shall:

- Allocate a confidential programme number to the issuing agent to facilitate the drawdown issuance process; and
- Confirm the eligibility of the programme to the issuing agent.

The issuing Agent shall request acceptance of the individual drawdowns to LuxCSD by referring to this confidential programme number. Upon acceptance of a new drawdown, LuxCSD confirms eligibility to the issuing Agent and the LPA.

Stand-alone

LuxCSD processes the acceptance of a new stand-alone Qualifying Security after receipt of the official issuance documentation.

Upon acceptance of a new stand-alone Qualifying Security, LuxCSD confirms the eligibility to the issuing Agent and the LPA.

1. Available from www.luxcsd.com.

Eligible jurisdiction

LuxCSD qualifying securities may require a legal opinion where both the governing law of the security and the country of incorporation of the issuer is not Luxembourg. The list of eligible jurisdictions is available on the LuxCSD website.

4.4 Closing activities

Distribution instructions

Depending on the model of issuance ("[Issuance models](#)"), instructions for the distribution of the security are required to be entered by the relevant seller and buyer(s). Counterparty settlement instructions shall match before becoming eligible for settlement on closing date.

FOP instructions are available if the cash leg of the distribution is executed externally.

Deposit of security

For LBN and LRN, the Issuer (Agent) shall arrange for deposit of the authenticated global certificate and accompanying legal documentation with the LuxCSD vault operator (LVO) by 12:30 on Closing Date.

Legal security documents shall be transmitted to LuxCSD via SwiftNet FileAct or any other agreed and authenticated communication method, ensuring the issuance of the securities without undue delay. Alternatively, delivery of the legal documents must be achieved by physical deposit at the LVO.

Legal security documents include:

- Issuer Effectuation and Disposal Authorisation (if applicable), and/or Effectuation Instruction. When the Effectuation and Disposal Authorisation is not required (for example, for physical deposit where effectuation language is not present on the certificate), LuxCSD recommends the delivery of the disposal instruction at the same time as the official security issuance documentation;
- Official security issuance documentation;
- GT certificate (to which final terms are attached where applicable) if the Terms and Conditions of the Qualifying Security provide that it first be issued in GT form;
- GP certificate (to which final terms are attached where applicable) if the Terms and Conditions of the Qualifying Security provide that it be issued in GP form.

For Qualifying Securities issued first in GT form, the Issuer or Agent may deliver both the GT and the GP certificates before or at the latest on closing date, or may decide to deliver the GP certificate at a later stage.

For LDN, the Issuer or Agent shall arrange for electronic transmission of the official Terms and Conditions to the LVO by 12:30 on Closing Date.

Note: Issuer Effectuation and Disposal Authorisation is not applicable for LDN.

Effectuation

For LBN and LRN, the LVO shall, upon verification of the received documents and where applicable, effectuate and send to LuxCSD and the LPA a confirmation of effectuation and of deposit. Such a confirmation can also be delivered by the LVO to the Issuer or its Agent upon request.

For LDN, the LVO shall, upon verification of the received documents, send the confirmation of receipt to the Issuer or its Agent upon request.

4. Issuance

Markup instruction

When all conditions precedent have been met and that closing (and registration where applicable) is effective, the LPA shall send the mark-up (MU) confirmation to LuxCSD. The MU confirmation must be received by LuxCSD at the latest by 14:00 on Closing Date to enable timely settlement and primary market distribution.

LuxCSD shall match the MU confirmation received from the LPA with the confirmation received from the LVO. In case of matching, LuxCSD shall mark up the issuance records in its books and will credit the Issuer (Agent) or the Lead Manager account, or any other beneficiary account indicated in the LPA MU confirmation, with the full issuance amount.

4.5 Primary market distribution

LuxCSD recommends Issuers, Agents and Lead Managers make use of segregated issuance accounts (also known as syndication accounts) to process primary market distributions. For distribution against payment, LuxCSD also recommends that the initial credit be made on an Issuer or Agent issuance account (Issuance model 1).

Upon credit of the securities on the Issuance account, distribution will take place against central bank money (CeBM) payment in the LuxCSD's daylight real-time processing environment, provided all counterparties have input appropriate LuxCSD settlement instructions and have ensured appropriate funding of their account in TARGET2 (T2S (DCA)).

Settlement of secondary market activity shall take place immediately thereafter.

Pre-closing

If the distribution is to be done through LuxCSD in "pre-closing", that is for settlement in the LuxCSD's night-time securities settlement processing cycle, the Qualifying Security and the accompanying documents or the Terms and Conditions (for LDN) shall be delivered to the LVO at the latest by 16:00 on closing date minus one business day, and the LPA's MU confirmation shall be received by LuxCSD by 18:00 on closing date minus one business day.

Free of payment

The Issuer or Agent shall deliver the certificate or Terms and Conditions (for LDN) to the LVO ahead of or at the latest by 16:00 on Closing Date. The LPA MU confirmation shall be received by LuxCSD by 17:00 on Closing Date. The lead manager (for syndicated issues) or the Issuer or issuing Agent controls the collection of subscription amounts separately from the distribution process.

LuxCSD shall match the MU confirmation received from the LPA and the confirmation received from the LVO. Upon successful matching, LuxCSD shall mark up its records and credit the Qualifying Securities on the beneficiary account.

4.6 Payment

Depending on the issuance model, subscribers (lead managers, allottees, dealers, custodians etc.) shall ensure that their LuxCSD T2S (DCA) sub-account is properly funded to ensure settlement in LuxCSD.

Upon settlement of the distribution leg, the issuance proceeds are credited to the Issuer or Agent account in T2S (DCA).

The distribution flows of cash and securities for a model 1 DVP syndication issuance flow is represented in “DVP Syndication Issuance (Model 1) Flow” and described below.

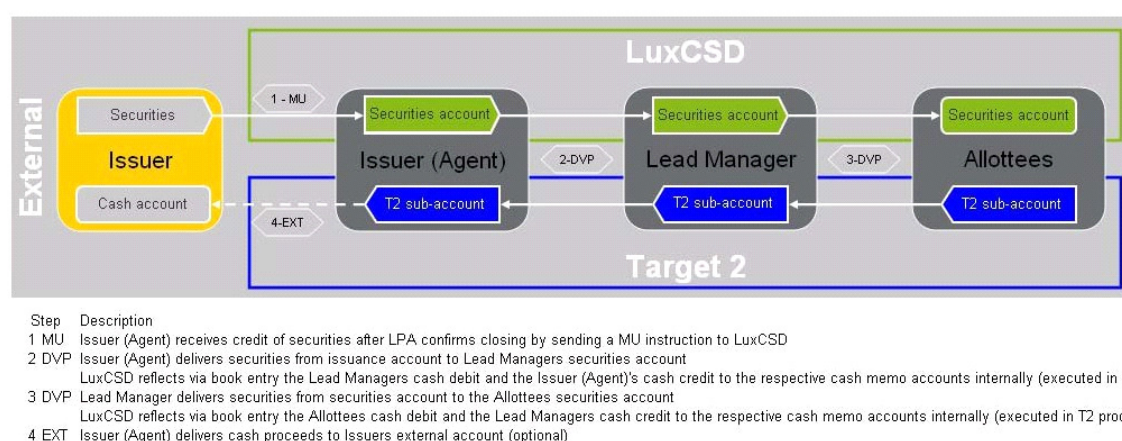

Figure 4-3. DVP Syndication Issuance (Model 1) Flow

4.7 Fungibility of tranches

Further tranches of existing Qualifying Securities may be issued which are or may become fungible with the initial offering of Qualifying Securities.

If all criteria for immediate fungibility are met, LuxCSD shall accept the new Qualifying Securities under the previously allocated ISIN for the initial offering. The new Qualifying Securities become automatically fungible with the initial Qualifying Securities as from the closing date of the new tranche.

LuxCSD Security Form	Delivery of a New Certificate	Delivery of new Terms and Conditions / Final Terms
LBN	Required	Required
LRN	Required	Required
LDN	Not required	Required

The distribution of such issue is the same as any standard issuance procedure, described here above.

If the criteria for immediate fungibility are not met, the NNA assigns a separate ISIN to the new tranche. In this case, a new certificate shall be delivered to LuxCSD (until the fungibility can be achieved). The distribution of such issue is the same as any standard issuance procedure, described here above.

4. Issuance

4.8 Summary of issuance timings

LuxCSD Issuance on Closing Date

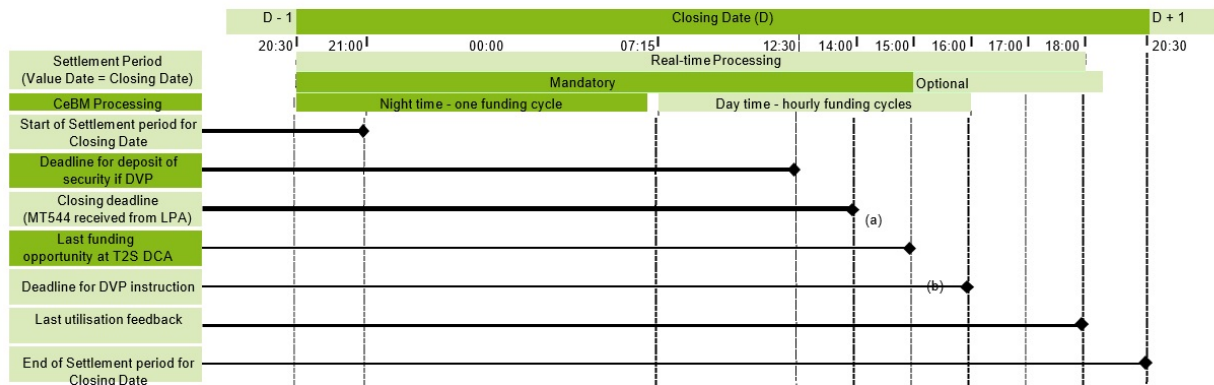

Deadline for NTP instructions

- Notes: (a) The LuxCSD closing deadline assumes counterparties are using the Creation settlement platform. LuxCSD recommends that the deadline be adjusted based on the location of the counterparties.
 (b) LuxCSD recommends that the Optional Settlement Flag be set to allow for settlement after the end of the Mandatory Period.

Figure 4-4. Summary of DVP issuance timings

5. Asset servicing

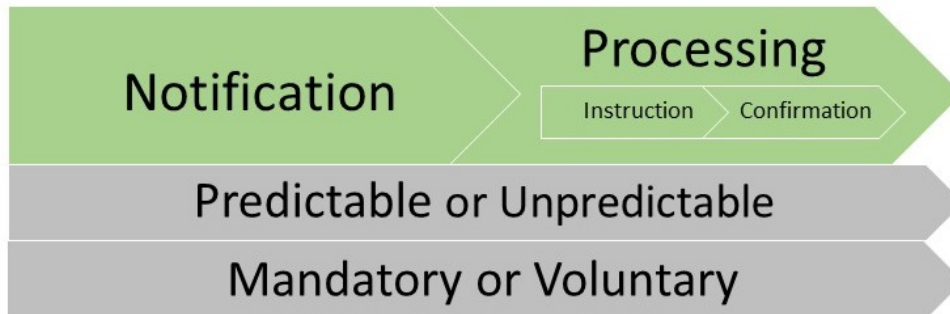

Figure 5-1. Asset Servicing events

5.1 Corporate action events

Corporate action events are those events covering income and non-income events.

LuxCSD implements the Market Standards on Corporate Actions produced by the Corporate Actions Joint Working Group (CAJWG). The market standards cover:

- Categories of Corporate Events:
 - Distributions (Cash, Security, including with options), and
 - Reorganisations (Mandatory, Mandatory with Options, and Voluntary).
- Information flow throughout the chain of relevant parties:
 - Key dates and their sequence, and
 - The operational processing of Corporate Actions.

LuxCSD implements the Market Standards for Transaction Management produced by Corporate Actions Sub-Group (CASG). The market standards cover:

- Market claims (reverse market claims)
- Transformations
- Buyer protection

The LPA shall provide a high quality of service in notifying and processing CA events, and in particular shall ensure a timely, complete, accurate, secure and automated information and communication to LuxCSD. See the LuxCSD Swift Guide for Agents for format and content of the information to be provided.

The LPA shall deliver the corporate event information based on timings defined in the Final and endorsed version of the Market Standards.

LuxCSD recommends the use of the ISMAG asset servicing checklists¹ for notification of Asset Servicing events.

1. Available at www.clearstream.com/ismag

5. Asset servicing

Notification

The LPA shall send a basic or a full event notification on the relevant notification date depending on the Corporate Action (CA) event type as defined in the Market Standards and the LuxCSD Swift Guide for Agents. Where complete information of the event is not available for the first notice (for example for conditional events), the LPA event notification shall contain the available information indicating that the information is definitive but incomplete.

The LPA shall further notify LuxCSD when:

- Complete definitive information is officially announced in the market or is obtained by the LPA on the day the information is announced, indicating the information is complete;
- Any amendments are announced the same day the amendment is announced in the market. The LPA shall advise LuxCSD whenever the terms of an income event change, via the same channel as used for the sending of notification;
- Proceed details are made available (that is details of the proceeds fixed before or at the execution of the CA instruction or event).

Authorised notification period to investors

For events for which an authorised notification period to investors is defined in the Terms and Conditions of the Qualifying Security or the event, the LPA shall apply the following rules when sending event notifications to the LuxCSD:

- For call options/early redemptions the LPA shall send the event notification to LuxCSD within the exercise period indicated in the Terms and Conditions in the case the issuer has decided to exercise its option.
- For other CA events the LPA shall send the event notification, including the “official announcement date to investors”, to LuxCSD as soon as announced ahead of such official announcement date.

LuxCSD shall release the information to clients after such official announcement date.

Processing

Payment claim

As LuxCSD holds 100% of the Qualifying Security, the Issuer or the paying Agent shall process the incoming payments without the receipt of a formal payment claim from LuxCSD. LuxCSD Cash Correspondent Bank (CCB) details will be made available to Issuers and Agents via the LuxCSD website. Any change of CCB details will be advised by LuxCSD to the LPA community at least five business days before the effective date.

Pre-advice

For each event with fund proceeds, the LPA shall validate the payment details with the relevant Agent to ensure proper payment of the funds to LuxCSD for good value. After validation, the LPA shall send to LuxCSD a confirmation that the relevant Agent has been instructed to pay and of the cash amount expected to be received (“pre-advice of funds”). A pre-advice shall be sent on payment date minus two business days.

In case of a change to the payment details occurring after the transmission of the original pre-advice of funds, the LPA shall immediately provide LuxCSD with an amended pre-advice of funds.

Upon receipt of funds

LuxCSD shall process payments to its participants upon reconciliation of fund proceeds.

The LPA shall assist LuxCSD in resolving any difference between the payment that has been pre-advised and the funds that have effectively been received, or between the pre-advised and/or paid

amount versus the LuxCSD expected amount. The LPA shall seek the assistance of the Agent whenever it is required.

In order to ensure timely reconciliation of amounts due and payment to LuxCSD's client, pre-advice of funds and payment claims must always be separated and must never aggregate expected payments in respect of different income events and/or issues.

Payment Deadline

Euro currency payments must be received before 12:00 on payment date to allow onward distribution to beneficiaries under good value. Euro payments received after 12:00 shall be distributed under good value on a best effort basis. Non euro currency payments should be received by LuxCSD as early as possible to allow for timely distribution to beneficiaries.

Payment confirmation

For each event with fund proceeds, the paying agent and/or LPA shall send a payment confirmation to LuxCSD after the payment has been executed. The payment confirmation allows for the faster onward distribution of funds due to improved reconciliation processing, especially in the case where the payment confirmation amount is different from the previously communicated payment amount (that is the pre-advice).

Redemption

Early, final or partial redemption (with or without decrease of nominal amount or via lottery), leading to a decrease of the IOA, the LPA shall transmit the mark-down (MD) confirmation to LuxCSD as soon as it is received from the Agent.

Partial redemption without reduction of nominal amount, LuxCSD shall not change the nominal amount of the notes but shall reflect the partial redemption by adapting the value of the pool factor. LuxCSD and the LPA shall continue to communicate on the basis of the original nominal amount of the notes. Upon receipt of the new pool factor from the Agent, the LPA shall send to LuxCSD a MD confirmation containing the new pool factor to LuxCSD.

LuxCSD recommends the use of partial redemption via pool factor rather than via the reduction of the nominal amount.

Partial redemption with reduction of nominal amount which results in new denominations without decimals, LuxCSD shall process the reduction of the nominal amount and communicate with the LPA on the basis of the new nominal amount.

Partial redemption with reduction of nominal amount which would result in a new denomination with decimals, LuxCSD shall process the partial redemption without reduction of nominal through the use of a pool factor as specified in the Terms and Conditions of the issue. Upon receipt of the new pool factor from the Agent, the LPA shall send to LuxCSD a MD confirmation containing the new pool factor to LuxCSD.

Lottery, the denominations do not change but the nominal amount is decreased.

Instruction provision

Where voluntary or mandatory options from investors are available, LuxCSD may instruct the LPA or the event agent directly. If the instruction transits via the LPA, the LPA shall forward it immediately to the event agent. LuxCSD instructions can be sent in two different modes, individually or summed, that is several CA instructions to LuxCSD can be summed into one CA instruction to the LPA/agent.

There are three possible timings for sending the CA instruction: continuously, once at the deadline or daily. The event agent's and the LPA's deadlines shall by default be the same date as the market deadline.

Where applicable, LuxCSD shall send a MD and/or a MU request to the LPA to advise it of a forthcoming MD confirmation and/or of a MU confirmation in order to facilitate IOA reconciliation.

5. Asset servicing

Event processing

- When the execution of an event implies a MD/MU, the issuer and its agents, including the LPA, shall ensure that all their obligations linked to the MD/MU for voluntary events and mandatory events with or without option(s) are performed. If proceeds of an event are a new Qualifying Security, the issuer or its agent shall arrange for the deposit of the appropriate documents with LVO and the LPA shall send the MU confirmation to the LuxCSD, in accordance with the new issues procedure.
- Upon CA Agent confirmation to the LPA of the payment of the cash proceeds, the LPA shall send a Confirmation of Payment to LuxCSD.
- When LuxCSD sends a CA instruction to the LPA/Agent where the event does not affect cash or security movements (for example voting), the LPA/Agent shall confirm the execution of the instruction.

Requests for return of funds

Issuers and Agents agree to abide by the LuxCSD Return of Funds policy to request the return of funds for payments made in error to LuxCSD.

If the Agent detects an error or a problem with the payment which requires the return of funds to the Agent, the Agent shall contact LuxCSD as soon as possible via MT564 adding the additional information in tag ADTX or MT568.

The MT564 or MT568 shall contain sufficient and clear information to identify the payment made in error and shall include:

- Payment details (ISIN code, amount paid, currency, value date etc...)
- The originator of the reversal (who): for example, Paying Agent Name
- The root cause (why): for example, Manual/Typing error
- The error (what): for example, pool factor

Note: No particular format is required. For further details about the Who, Why and What content refer to the LuxCSD Swift Guide for Agents - ISMAG Reversals root cause analysis.

Upon receipt of such notice, LuxCSD shall notify its clients in accordance with its General Terms and Conditions to return the funds as per the Agent's instruction and upon receipt of the returned funds LuxCSD shall instruct payment to the Agent.

5.2 Meeting notifications and proxy voting

The LPA shall provide the service for general meetings of all Qualifying Securities

The LPA shall send a full event notification to the LuxCSD of a forthcoming meeting on the Qualifying Securities on the announcement date of the meeting and in line timings defined in the final and endorsed version of the Market Standards. The MT564 notification shall contain sufficient and clear information related to the meeting and shall include:

- Security details and meeting type;
- Meeting date and time,
- Voting option number and voting option type,
- Indication whether instruction on beneficial owner level is required,
- Indication if an event has a record date or if blocking is applicable,
- LPA's and market's deadline for receipt of LuxCSD's voting instructions,

- Indication of any special requirement of the issuer.

Upon request of LuxCSD, The LPA shall also send meeting agenda/notice in English.

Proxy voting instructions and status

LuxCSD's instructions may consist of:

- Security details and meeting type;
- Voting option number and voting option type;
- Instructed amount;
- Beneficial owner's details, if applicable;
- Attendees' details, if applicable.

Result dissemination

The LPA shall notify LuxCSD of the results of all the meetings where a LuxCSD client was represented at the latest on the day following receipt of the results from the issuer or the Agent but no later than 5 BD after the meeting date.

When the conclusion of such a meeting leads to the triggering of an unpredictable event, the LPA shall send a basic event notification to LuxCSD describing the resulting events.

5.3 Shareholder Rights Directive (SRD) II specific provisions

Shareholder disclosure under the SRD II

For shareholder disclosure requests for which the LPA has been delegated by the issuer to send a request and / or to receive responses and other actions, the LPA will promptly notify LuxCSD of such request as per Appendix 5 "Communication formats for Corporate Actions under the Shareholder Rights Directive II".

Meeting notifications and proxy voting under the SRD II

For meeting notifications for which the LPA has been notified by the issuer that the meeting falls under the Shareholder Rights Directive, the LPA will promptly notify LuxCSD accordingly, as per the agreed templates ("SRDII flag" will be used) in Appendix 5 "Communication formats for Corporate Actions under the Shareholder Rights Directive II".

In addition, the LPA will provide the acknowledgement of receipt by the issuer of the voting instruction as well as the vote execution confirmation, when such a confirmation has been requested in the voting instruction of LuxCSD and when such confirmation has been received from the issuer.

5.4 Exchange GT to GP and fungibility

LuxCSD offers a fully automated procedure for processing TEFRA D securities only within the certification period.

Where a security becomes fungible post issuance, LuxCSD shall process the fungibility in a similar manner to the Exchange GT to GP. The relevant instructions are available in the LuxCSD Swift Guide for Agents, with the primary difference being the need to identify the old (mother) and new (daughter) tranche ISIN's.

Authorisation

LuxCSD shall request an authorisation from the Issuer (via the LPA) to process all exchanges from GT to GP with the corresponding updates of the IOA as of exchange date and thereafter.

Certification

Where LuxCSD require client certifications and the appropriate Qualified Investor Certification is not provided by the certification due date, the uncertified or non-qualified investor position in the relevant security will be automatically blocked.

Exchange

At exchange date and after receiving the authorisation, LuxCSD shall exchange from GT to GP. Blocked positions shall not be exchanged and shall not be eligible for any entitlement.

Blocked positions can be exchanged later upon delivery of appropriate certification and validation with the Issuer or Agent.

5.5 Disposal process

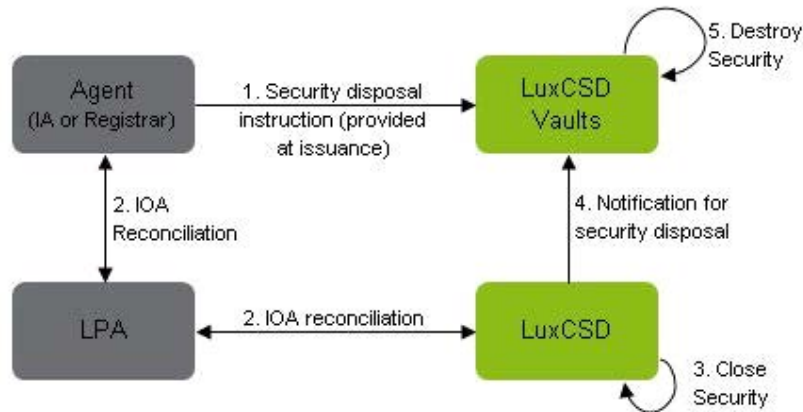

No.	Timing	Action
1	<= Closing Date	Agent instruction for security destruction of the security (provided at issuance via Effectuation and Disposal Autorisation)
2	>= Maturity Date	Reconciliation of securities IOA equal to zero as maturity date reached, or no further mark-up possible
3		Close security
4	Disposal Date	Notification to Vaults for disposal
5	>= Disposal Date	LuxCSD Vaults destroy the security

Figure 5-2. Securities End of Life

For LBN and LRN securities, the LPA shall initiate the reconciliation to LuxCSD at the securities end of life. After successful reconciliation, LuxCSD shall close the LBN and/or LRN security or cancel the LDN security records and reduce the Issuance account ("compte d'émission") to zero, ensuring no further transactions take place.

For LBN and LRN securities, the Agent disposal authorisation is sent to the LVO to confirm the disposal process at the same time as the official security issuance documents (see "[Closing activities](#)").

On LBN and LRN disposal date or LDN cancellation date, and after reconciliation has been completed, LuxCSD shall send a notification to the LVO for the security disposal.

The LVO shall dispose of the LBN and/or LRN security only upon receipt of both the Agent disposal authorisation and the LuxCSD disposal instruction.

For LDN securities, the LPA shall initiate the reconciliation to LuxCSD at the securities end of life. After successful reconciliation, LuxCSD shall cancel the security records and reduce the Issuance account ("compte d'émission") to zero, ensuring no further transactions take place.

The Agent cancellation authorisation is sent to the LVO to confirm the cancellation of such security's position in the Issuance account from the LuxCSD's book as OL (see "[Closing activities](#)").

On cancellation date, upon receipt of the LPA notification and after reconciliation has been completed, LuxCSD shall cancel the security's position in the Issuance account.

5.6 Tax information and processing

The LPA shall assist LuxCSD to:

- Determine the tax treatment of Qualifying Securities; and
- Identify any amendment to such rules, treaties or practices and notify LuxCSD immediately;
- Arrange for withholding tax relief to be applied through Relief At Source and Standard/Quick Refund Tax Procedures, whenever possible.

In the context of withholding tax relief, the LPA shall:

- Provide information to LuxCSD on the tax treatment of Qualifying Securities;
- Apply LuxCSD tax relief procedures as published from time to time on its website. Any new procedure or change to existing procedures will be made available to the LPAs at least five business days before effective date; and
- Take all necessary actions to process and follow-up on withholding tax relief claims.

5.7 Record keeping

The LPA shall at all times maintain records and data on all the services and activities as set forth in these operational arrangements. All records maintained pursuant to this Section shall be retained by the LPA for such period as shall be required by law, but in no event for less than ten years, where after retention of such records shall be at the LPA's discretion.

Records of static information (as described in this document) shall be retained by the LPA for a period of ten (10) years as from the termination of this Agreement. Records of dynamic information (for example, securities transactions details, balances, movements) shall be retained by the LPA for a period of ten (10) years as from the creation of such information.

The LPA shall make such records available, upon request, to LuxCSD competent or other relevant authority that has a power to request access to such records for the purpose of fulfilling their mandate and to LuxCSD if it has been required by such authority to make records and data available.

5.8 Reconciliation

Reconciliation of the IOA shall take place between LuxCSD and the Issuer or Agent via the LPA and LuxCSD.

The Agent or the LPA shall implement adequate reconciliation procedures to enable LuxCSD to perform its reconciliation duties in compliance with the applicable laws and regulations and ensure the overall integrity of the issue.

Note: Step 4 is not applicable to LDN.

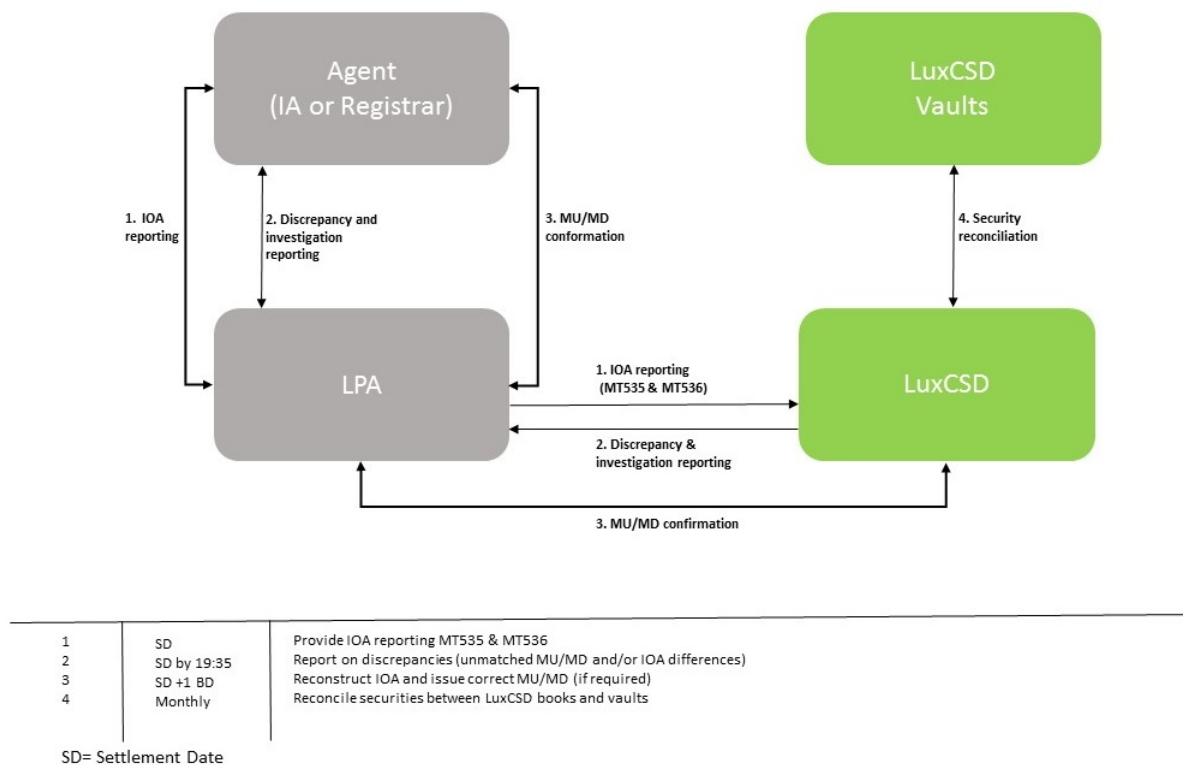

Figure 5-3. Reconciliation

Daily reconciliation

The LPA and LuxCSD shall undertake a complete (that is for all Qualifying Securities) daily IOA reconciliation exercise (and the pool factor when relevant).

- LuxCSD has received on that day a MD/MU confirmation from the Agent, or delivered a CA instruction or a MD/MU request to the Agent; or
- There is an income event with payment date (PD) = current date + five business days or with record date = current date + two business days (whichever is the earlier) or a CA event with an event date = current date + five business days or with record date = current date + two business days (whichever is the earlier); or
- A discrepancy in the IOA has been detected in a previous reconciliation process and the discrepancy is not yet solved or has been solved on the day the report is being produced; or

5. Asset servicing

- The Agent has reversed a MD/MU confirmation following the receipt of a MD/MU rejection message from the LuxCSD.

This shall include:

- at least a daily reconciliation of the total balance recorded on the securities accounts maintained by LuxCSD with the corresponding records of the Securities maintained by the Issuer or any agent appointed by the Issuer with respect to the Securities, as the case may be;
- where the Securities have been transferred during a given business day and to the extent it is possible given the nature of the Securities, an end of day reconciliation of the balance of each securities account maintained by LuxCSD with the balance of the corresponding record of the Securities maintained by Issuer or any agent appointed by the Issuer with respect to the Securities, as the case may be.

Reconciliation between the LPA and third parties

If a third party such as the issuer, registrars, issuance agents, transfer agents or other entities maintain records of a Qualifying Security which are also recorded in the LPA, the LPA shall involve these third parties to perform the daily reconciliation process of that Qualifying Security to maintain its integrity.

In case a Qualifying Security is an investment fund, the LPA shall reconcile as often as the NAV is calculated, the total balance of all Qualifying Securities recorded on the securities accounts maintained by the LPA with the corresponding records of securities maintained by the third party, that is, the Transfer Agent, fund manager or other similar entity.

For all other Qualifying Securities, the LPA shall reconcile daily (applying the pool factor when relevant) the total balance of all Qualifying Securities recorded on the securities accounts maintained by the LPA with the corresponding records of securities maintained by the third party if:

- the securities have been transferred during a given business day; and/or
- the LPA has received on that day a MD/MU confirmation from the Agent, a CA instruction or a MD/MU request from LuxCSD; and/or
- there is an income event with $PD = \text{current date} + 5 \text{ business days}$ or with $\text{record date} = \text{current date} + 2 \text{ business days}$ (whichever is the earlier) or a CA event with an event date = current date + 5 business days or with $\text{record date} = \text{current date} + 2 \text{ business days}$ (whichever is the earlier); and/or
- a discrepancy has been detected in a previous reconciliation process and the discrepancy is not yet solved or has been solved on the day the report is being produced; and/or
- the LPA has reversed a MD/MU confirmation following the receipt of a MD/MU rejection message from LuxCSD.

Additionally, the LPA shall:

- on a daily basis, reconcile any notification received through the information exchange measures put in place on the day of its receipt, sent by the third party with regard to the total balance of all Qualifying Securities maintained by that third party; and
- at least every two weeks, perform a full reconciliation of all balances in a securities issue with all balances on the corresponding record of securities maintained by the relevant entity.

Reconciliation between the LPA and LuxCSD

The LPA shall provide:

- LuxCSD with a daily statement of transactions by 20:30, listing all the movements booked on the LuxCSD account (including booking of MD/MU, reversals of rejected MD/MU);
- LuxCSD with a daily statement of holdings by 20:30, listing the closing balance at end of the current business day (in line with all the movements reported in the above statement of transactions) for all Qualifying Securities.

Reconciliation by LuxCSD

LuxCSD shall reconcile, on a daily basis, the statement of transactions and the statement of holding listing the own LuxCSD's positions as received from the LPA, with its internal records and shall report any discrepancy detected to the LPA for further investigation by the LPA.

LuxCSD shall also report to the LPA any missing MD confirmations, for example, the positions for which a MD confirmation is expected from the Agent and has not yet been received because a CA or repurchase instruction has been sent or because the event date has been reached.

Investigation of discrepancies between the LPA and third parties

The LPA shall take all the necessary actions to resolve any discrepancy between the records maintained by the Agent and LuxCSD's positions maintained by the LPA on the same day as reported by the Agent and at the latest on the next business day.

The LPA shall regularly provide a status update of the investigation related to the identified discrepancy to LuxCSD via email

For any discrepancy reported by the Agent on a business day on which an income claim has to be made, on a CA deadline date, on a CA record date, on the business day preceding a CA event date or on the business day preceding a coupon or redemption payment date, all efforts shall be deployed by the LPA to resolve the discrepancy on that day.

Should the above described discrepancy remain unresolved on that day, the LPA shall:

- inform directly LuxCSD of such difference, keep any MD confirmations received in suspense and investigate directly with the Agent to resolve the discrepancy;
- request instruction from LuxCSD on how to proceed with the MD confirmation received and with the position in suspense. This is an escalation procedure whereby the LPA is required to telephone the escalation person within the relevant operational department as per Appendix 2 dealing with the event and send the details via email or Swift according to the situation. The LPA shall keep in regular contact with the relevant operational department until such time as LuxCSD has provided the LPA with instructions on how to proceed with the confirmation received.

Investigation of discrepancies between the LPA and LuxCSD

Once the reconciliation process is completed (described in "[Daily reconciliation](#)", "[Reconciliation between the LPA and third parties](#)", "[Reconciliation between the LPA and third parties](#)", "[Reconciliation by LuxCSD](#)") and if the LPA or LuxCSD identify any discrepancy it shall:

- start the investigation of any discrepancy, without undue delay; and
- take all the necessary actions externally and internally; and
- endeavour to resolve the discrepancy as soon as possible.

The LPA shall also start the chasing of missing MD/MU confirmations and shall provide a daily update of the status.

5. Asset servicing

For any discrepancy reported by LuxCSD on a business day on which an income claim has to be made, on a CA deadline date, on a CA record date, on the business day preceding a CA event date or on the business day preceding a coupon or redemption payment date, all efforts have to be deployed to resolve the discrepancy on that day.

The LPA shall regularly provide a status update of the investigation related to the identified discrepancy to LuxCSD via email as per the contact list.

5.9 Reconciliation reporting

Reporting by the LPA

Unresolved discrepancies between the LPA and any third party will be reported by the LPA to LuxCSD by a daily report listing the discrepancies. This report (Appendix 3) shall contain the above mentioned number of limited Qualifying Securities:

- all the discrepancies reported by the third party on that given date;
- all the discrepancies previously reported by the third party but not yet solved;
- all the discrepancies previously reported by the third party and solved on that given date.

The LPA shall send the report via email to the address specified in Appendix 2.

The report (even if empty) shall be sent on a daily basis.

Reporting by LuxCSD

On a daily basis, after their own reconciliation process, LuxCSD will follow up and start an investigation with the LPA on:

- all discrepancies resulting from the reconciliation process that could potentially result in the creation or deletion of securities;
- missing MD/MU confirmations.

LuxCSD will send above mentioned investigation in the form of a consolidated report. The LPA shall verify the consolidated report and confirm/update the status of the investigation at the latest, close of business on the next business day.

Identification of undue creation or deletion of securities and suspension of settlement

LuxCSD and the LPA shall analyse any mismatches and inconsistencies resulting from the reconciliation process and take all relevant measures to resolve them. Once the results of the investigation confirm that the discrepancy is the result of an undue creation or deletion of securities, LuxCSD or the relevant LPA shall:

- inform of their findings to the relevant party(ies), via email to the advised email address; and
- endeavour to resolve the undue creation or deletion of securities before 17:00 on the business day immediately following the final conclusion that the break resulting from the reconciliation process is a consequence of an undue creation or deletion of securities took place;
- If the discrepancy due to an undue creation or deletion of securities is still not resolved by 17:00 CET (on the next BD following the day of conclusion of an undue creation or deletion of securities), LuxCSD shall decide to suspend all settlement in the relevant security until resolution of the undue debit or credit of securities.

If LuxCSD decides to suspend all settlement, they shall communicate such decision to the LPA by 17:00 via MT599 and via email to the relevant email address.

Resolution of undue creation or deletion of securities

Once the discrepancy is resolved, LuxCSD will inform the LPA accordingly.

In the case suspension of settlement has been applied, LuxCSD will also confirm to the LPA the decision to lift the settlement suspension after the undue creation or deletion of securities has been resolved.

The resolution of the undue creation or deletion of securities and lifting of any suspension is to be communicated by 17:00 and via MT599 and via email to the relevant email address.

Undue creation or deletion of securities reporting data

Communication means to be used by LuxCSD and/or LPA to inform each other and the relevant parties of the identification of an undue creation/deletion of securities or for LuxCSD to inform LPA of a suspension/to lift suspension of settlement.

Action	Media	Content
Undue creation/deletion of securities	Email	<ul style="list-style-type: none"> • ISIN + issue name • Date of identification of undue creation or deletion • Context: CSDR - mismatch with undue creation/deletion
Suspension/to lift suspension of settlement	MT599 and Email	<ul style="list-style-type: none"> • ISIN + issue name • Date of suspension date/ lifting date • Context: CSDR - suspension date/lifting date

Qualifying Securities with pool factor

Upon receipt of the confirmation of the new pool factor from the Agent, the LPA shall quote the new pool factor value on the statement of holdings as from actual payment date plus one business day (dated actual payment date) for IOA reconciliation purposes.

Before that actual payment by the Issuer, the pool factor reported in the statement of holding shall be the pool factor that applied before the payment.

The Agent, via the LPA, and LuxCSD shall reconcile the pool factor value as reported on the statement of holdings.

5. Asset servicing

This page has intentionally been left blank.

6. Performance monitoring

The objective of LuxCSD is to provide an efficient environment for securities issuance, settlement and servicing. To this effect, LuxCSD shall monitor and report on market performance to assess the level of achievement in respecting market best practices. This continual monitoring shall enable the market participants and LuxCSD to assess areas where further efficiency improvements may be achieved.

6. Performance monitoring

This page has intentionally been left blank.

7. Business continuity and disaster recovery

The LPA shall implement adequate business continuity and disaster recovery arrangements. The LPA shall make such arrangements available to LuxCSD upon request.

The LPA shall participate in the design and conduct of any such testing upon request from LuxCSD.

7. Business continuity and disaster recovery

This page has intentionally been left blank.

Appendix 1. Swift messages summary

MTnnn	Section	Sub Section	Description of the message	Sender	Receiver
MT535	Statement of Holdings				
	Reconciliation		Daily statement of IOA	LPA	LuxCSD
MT536	Statement of Transactions				
	Reconciliation		Daily statement of transactions	LPA	LuxCSD
MT542	Deliver Free				
	Accounting	MU/MD of securities	Cancellation of repurchase instruction	LuxCSD	LPA
		MU/MD of securities and Repurchase	Repurchase instructions	LuxCSD	LPA
MT544	Receive Free Confirmation				
	New Issues		MU confirmation for a New Issue distribution.	LPA	LuxCSD
	Accounting	MU/MD rejection processing	Reversal message and corrected message in case a new issue is rejected by the LuxCSD	LPA	LuxCSD
MT546	Deliver Free Confirmation				
	Accounting	MU/MD rejection processing	Reversal message and corrected message in case a MU/MD confirmation related to repurchase	LPA	LuxCSD
		MU/MD of securities and Repurchase	MD confirmation of repurchases	LPA	LuxCSD
MT548	Settlement Status and Processing Advice				
	New Issues (LVO)		Deposit confirmation/rejection	LuxCSD	LPA
	Repurchase		Status report on repurchase instruction sent only in case of problem (including unmatching feedback) or rejection	LPA	LuxCSD

MTnnn	Section	Sub Section	Description of the message	Sender	Receiver
MT564	Corporate Action Notification				
	Corporate Actions	Information provision	Notification of CA events	LPA	LuxCSD
			Notification of proceed details	LPA	LuxCSD
		Exchange GT/GP	Prior authorisation confirming that the LuxCSD can process a fungibility or a GT/GP exchange	LPA	LuxCSD
		Exchange GT to definitive notes	Notification confirming that the agent is ready to process the exchange into definitive notes	LPA	LuxCSD
	Income		Notifications of any variable details of income and redemption events	LPA	LuxCSD
			Pre-advice of funds	LPA	LuxCSD
			Pre-advice of taxable funds with instruction	LPA	LuxCSD
			Amended pre-advice of funds	LPA	LuxCSD
MT564 (plus MT568 for more details, if applicable)	Corporate Actions	Meeting	Notifications of meeting event	LPA	LuxCSD
	Tax		Notification including certification request	LPA	LuxCSD

MTnnn	Section	Sub Section	Description of the message	Sender	Receiver
MT565	Corporate Action Instruction				
	Accounting	MU/MD of securities and Corporate Actions	MD request for CA events	LuxCSD	LPA
			CA instruction	LuxCSD	LPA
		MU/MD of securities	Cancellation of MD request	LuxCSD	LPA
			Cancellation of CA instruction	LuxCSD	LPA
	Corporate Actions	Certification	Certificate instruction from LuxCSD	LuxCSD	LPA
		Exchange GT/GP	Request to update the position for the processing of a fungibility or an exchange from GT to GP form	LuxCSD	LPA
		Exchange GT to definitive notes	Advice to update the position for the processing of an exchange from GT form into definitive notes	LuxCSD	LPA
		Consent	Consent instruction	LuxCSD	LPA
		Meeting	Voting instruction	LuxCSD	LPA
	Corporate Actions	Meeting under SRD II	Voting instruction under SRD II	LuxCSD	LPA
	Tax		Tax certification instruction	LuxCSD	LPA

MTnnn	Section	Sub Section	Description of the message	Sender	Receiver
MT566	Corporate Action Confirmation				
	Accounting	MU/MD of securities and Corporate Action	Confirmation of CA events (including MU/MD confirmation for CA events and including credit of newly issued securities resulting from a CA event)	LPA	LuxCSD
		MU/MD of securities and Income	MD confirmation for redemptions	LPA	LuxCSD
		MU/MD of securities - pool factor redemption - and Income	MD confirmation for pool factor after actual payment by issuer	LPA	LuxCSD
		MU/MD rejection processing	Reversal message and corrected message in case a MU/MD confirmation related to CA events is rejected by the LuxCSD	LPA	LuxCSD
	Corporate Actions	Exchange GT/GP	Confirmation of processing of a fungibility or for an exchange from GT to GP	LPA	LuxCSD
		Exchange GT to definitive notes	Confirmation of mark-down of the GT form	LPA	LuxCSD
		Meeting	Meeting Result Notification (for cash proceeds if any)	LPA	LuxCSD
		Consent	Consent results notification (for cash proceeds if any)	LPA	LuxCSD
	Income		Confirmation of payment	LPA	LuxCSD
MT566 (for cash proceeds, if any) MT568 (for results)	Corporate Actions	Meeting under SRD II	Meeting Result Notification under SRD II	LPA	LuxCSD

MTnnn	Section	Sub Section	Description of the message	Sender	Receiver
MT567	Corporate Action Status and Processing Advice				
	Corporate Actions	Instruction status report	Status report on CA instructions and MD requests related to CA event	LPA	LuxCSD
	Accounting	MU/MD of securities	Reporting of matching discrepancy between:	LPA	LuxCSD
			- MD confirmation from the Agent, and	LPA	LuxCSD
			- MD request or CA instruction from the LuxCSD	LPA	LuxCSD
MT567 (if requested in MT565)	Corporate Actions	Meeting under SRD II	Vote Execution Confirmation	LPA	LuxCSD

MTnnn	Section	Sub Section	Description of the message	Sender	Receiver
MT568	Corporate Action Narrative				
	Accounting	MU/MD of securities	Instruction from LuxCSD to LPA to reject a MU/MD confirmation	LuxCSD	LPA
	Corporate Actions	Exchange GT/GP	Request for prior authorisation for the processing of a fungibility or a GT/GP exchange	LuxCSD	LPA
		Consent	Consent results notification (with no cash proceeds) and reporting of an extension of consent deadline	LPA	LuxCSD
		Meeting	Meeting Result Notification	LPA	LuxCSD
MT599	Free Format Message				
	Accounting	Chasing and investigation	Escalation for status update on missing MU/MD confirmation	LuxCSD	LPA
	New Issues		Notification by LuxCSD that the code or the program is opened, and of the LPA and the issue details	LuxCSD	LPA IA/LM
				Notification by LPA to LuxCSD in case of delay of closing date	LPA
	Reconciliation		Cancellation Notification of the security's position in the Issuance account by the LPA to the LVO for LDN	LPA	LuxCSD
XLS file via Email					
	Reconciliation		Reporting of reconciliation discrepancies between the IOA maintained by Agent and LPA	LPA	LuxCSD
				Reporting on reconciliation discrepancies detected by the LuxCSD, including missing MD confirmation	LuxCSD

Seev	Section	Sub Section	Description of the message	Sender	Receiver
seev.045 Shareholders Identification Disclosure Request					
	Corporate Actions	Request	Notification of mandatory shareholder disclosure request	LPA	LuxCSD
seev.046 Shareholders Identification Disclosure Request Cancellation Advice					
	Corporate Actions	Cancellation Advice	Cancellation of mandatory shareholder disclosure request	LPA	LuxCSD
seev.047 Shareholders Identification Disclosure Response					
	Corporate Actions	Response	Response of mandatory shareholder disclosure request	LuxCSD	LPA
seev.048 Shareholders Identification Disclosure Response Cancellation Advice					
	Corporate Actions	Cancellation Advice	Response Cancellation of mandatory shareholder disclosure request	LuxCSD	LPA
seev.049 Shareholders Identification Disclosure Response Status Advice					
	Corporate Actions	Status Advice	Status advice of mandatory shareholder disclosure request	LPA	LuxCSD

Appendix 2. Contact list

To be provided separately and to be updated from time to time and when deemed necessary.

This page has intentionally been left blank.

Appendix 3. Reconciliation discrepancy template

Reconciliation date	Agent ID	Agent name	First failed attempt	Common Code	ISIN	Reported code	Security name

Position type	Adjusted Basis balance	Adjusted Comparison balance	Transmitted	Remaining difference	Status	Settlement difference amount	Notes

This page has intentionally been left blank.

Appendix 4. Data Protection

1. The LPA may, during the performance of the services hereunder, have access to and process Personal Data of LuxCSD, including its employees, contractors, agents, Beneficiary and client, and shall comply with all Data Protection applicable laws as a Data Processor on behalf of LuxCSD as a Data Controller.
2. The LPA shall treat all Personal Data that it receives or becomes aware of pursuant to this Agreement as confidential.
3. The LPA shall ensure that the Personal Data is only accessible to personnel on a need-to-know basis in connection with the LPA's obligations under this Agreement.
4. If the LPA wishes to transfer Personal Data under this Agreement to a country outside of the EU that does not provide an adequate level of data protection (approved by an adequacy decision of the European Commission), the LPA, shall only transfer any such Personal Data except as provided in the Data Protection Applicable Laws, if (i) it is legally permitted (for example, it is necessary for the provision of the services), (ii) the relevant data controller as data exporter enter prior transfer/access into a data transfer agreement based on the model clauses for the transfer of Personal Data to Data Controllers or Data Processors established in third countries as approved by an EU Commission decision and its amendments with the receiving party in a third country as Data Importer and, if mandatory, by local applicable data protection law, (iii) the relevant Data Controller received prior approval of the competent authority for a Personal Data related third country transfer/access.
5. Subject to the obligations set forth in this Appendix 4, where the LPA acts as the Data Processor, the LPA shall at all times process the Personal Data solely upon instructions and for the purposes determined by LuxCSD for their respective Personal Data and comply with its obligations as Data Processor as follows:
 - implement technical and organisational measures to protect Personal Data against (a) accidental or unlawful destruction, (b) accidental loss, alteration, unauthorised disclosure or access and (c) against all other unlawful forms of processing, it being understood that, subject to costs and then-available technical know-how, these measures shall provide an appropriate level of security relative to the risk of disclosure in connection with the processing of and nature of the Personal Data. These measures will prevent any unnecessary collection and further processing of the Personal Data;
 - keep Personal Data only for as long as is reasonably necessary for the provision of the services under this Agreement or as required by applicable law.
6. Upon reasonable request of LuxCSD, the LPA shall (a) cooperate with and assist LuxCSD in complying with its obligations as Data Controller and in responding to requests for exercising the Data Subject's rights set out in the Data Protection applicable laws; (b) make available to LuxCSD, where applicable, all information reasonably necessary to demonstrate compliance with its obligations hereunder.
 - As soon as reasonably practicable, inform LuxCSD if:
 - it is unable to comply with its obligations under this Agreement because of legal requirements;
 - it receives an inquiry, a subpoena or a request for inspection or audit from a competent public authority relating to the processing of Personal Data;
 - it intends to disclose Personal Data to a competent public authority, provided it is permitted by applicable law;
 - it detects or reasonably suspects that an unauthorised acquisition, access, use, loss, theft, destruction or disclosure of Personal Data ("Data Security Breach") has occurred.
 - Promptly take adequate remedial measures in the event of a Data Security Breach, and provide LuxCSD with all relevant information as requested by it regarding a Data Security Breach. The LPA shall fully cooperate with LuxCSD to develop and execute a response plan to address the Data Security Breach;

- Use of sub-contractors is only permitted with the prior written consent of the LuxCSD. The LPA must set out the contractual agreements with the sub-contractor(s) in such a way that they reflect the data protection provisions agreed on between LuxCSD and the LPA.

Where a sub-contractor is used, LuxCSD must be granted the right to monitor and inspect the sub-contractor in accordance with this Agreement and with applicable Data Protection law. This also includes the right of LuxCSD to obtain information from the LPA, upon written request, on the substance of the contract and the implementation of the data protection obligations within the sub-contractual relationship, where necessary by inspecting the relevant contract documents.

7. The LPA shall return or delete, at the choice of LuxCSD, the Personal Data upon the termination of the provision of services as set out hereunder or in accordance with the Data Protection applicable laws, except to the extent that such return or destruction is prohibited by the laws or regulations applicable in the country in which the LPA carries out the processing. Where such a return or destruction is prohibited, the remaining Personal Data must be kept confidential and no longer be processed by the LPA.

Appendix 5. Communications formats for Corporate Actions under the Shareholder Rights Directive II

1. For SID requests under SDRII: SMPG compliant ISO 20022 Swift templates (SMPG CA on MyStandards site¹).
2. Templates SRDII Swift ISO 15022 General meetings messages.docx

1. https://www2.swift.com/mystandards/#/group/SMPG_CA!usage_guidelines.

This page has intentionally been left blank.

Appendix 6. Signature Page

Note: This Document may be executed by electronic signature and the Parties agree that the execution by electronic signature shall be as valid and as conclusive of their intention to be bound by this Document as if this Document was signed by the Parties' manuscript signatures.

Each Party hereby expressly acknowledges and agrees that the execution of this Document by their authorised representative via the abovementioned electronic process is made in full knowledge of the technology implemented, any related terms of use and in compliance with the applicable electronic signature laws and regulations, and accordingly, to the extent permitted by law, hereby irrevocably and unconditionally waives any right such Party may have to initiate any claim and/or legal action, directly or indirectly arising out of or relating to the reliability of said electronic signature process and/or the evidence of its intention to enter into this Document.

For and on behalf of the Agent (_____) acting as:

- Principal Agent
- Transfer Agent
- Fund Settlement Agent

Authorised Signature

Authorised Signature

Name

Name

Title

Title

For and on behalf of LuxCSD S.A.

Authorised Signature

Authorised Signature

Name

Name

Title

Title

This page has intentionally been left blank.

Glossary

This Glossary is intended for information purposes only and is designed to help clients to understand the terminology used by LuxCSD in this Handbook. In some cases, the way in which the terms are used in LuxCSD may differ from how the terms may be applied in another context. The descriptions given are not to be considered as legally binding definitions of the terminology used.

LuxCSD gratefully acknowledges that some definitions given here are based on those used by the Group of Thirty, the International Society of Securities Administrators (ISSA), and in other market publications.

A

Agent

A generic term describing a legal person that acts in the name and on behalf, and upon request, of the Issuer. The term "Agent" includes any LuxCSD Principal Agent, Paying Agent, Issuing and Paying Agent, Fiscal Agent, Registrar, Determination Agent, Calculation Agent, Withholding Agent (if appointed by the Issuer), Corporate Action Agent, Conversion Agent, Exchange Agent or any other Agent appointed by the Issuer.

B

Business Day

A day on which LuxCSD is open for business.

C

CA

Corporate Action.

CBL

Clearstream Banking Luxembourg.

CCB

Cash Correspondant Bank

CD

Certificate of Deposit.

CeBM

Central Bank Money.

CoBM

Commercial Bank Money.

Closing Date

The date on which the issue proceeds are paid to the Issuer and the securities are created and distributed to investors.

CP

Commercial Paper.

E

Entitlement Date

Any distribution of cash or securities, being the payment due date, as determined by the terms and conditions, for cash or the settlement date for securities.

G

GP

Permanent Global Note.

GT

Temporary Global Note.

I

IA

Issuer Agent.

IOA

Issued Outstanding Amount.

For a debt security: the total remaining indebtedness of the Issuer as determined from time to time.

For an equity instrument: the total remaining amount of units in existence. Where relevant, the IOA is the result of the product between the nominal amount and the pool factor of the security.

ISIN

International Securities Identification Number.

ISMAG

International Securities Market Advisory Group (www.clearstream.com/ismag)

Issuer

An entity issuing securities.

Issuance Account

Issuance Account ("Compte d'émission"), the account in LuxCSD that holds the total indebtedness of the Issuer for LDN.

Issuance Memorandum Account

The account in LuxCSD that holds the total indebtedness of the Issuer (that is Issue Outstanding Amount for LBN/LRN and compte d'émission for LDN).

L

LBN

LuxCSD Bearer Global Note.

LDN

LuxCSD Dematerialised Note.

LM

Lead Manager. An entity appointed by the Issuer to structure and lead the placement of a Syndicated Issue.

LPA

LuxCSD Principal Agent. An Agent appointed by the Issuer providing a central point of communication to LuxCSD.

LRN

LuxCSD Registered Global Note.

LuxCSD

LuxCSD, société anonyme, acting as a Central Securities Depository located in Luxembourg.

LVO

LuxCSD acting in its role as Vault Operator.

M

MD

Mark-Down. A decrease in the IOA of a Qualifying Security.

MTN

Medium Term Note.

MU

Mark-up. An increase in the IOA of a Qualifying Security.

N**NNA**

National Numbering Agency.

O**OL**

Organisme de liquidation. Securities settlement system as defined by the Luxembourg law dated 10 November 2009 on payment services, designated as such by the Banque Centrale du Luxembourg, notified to the European Commission by the Ministry in charge of the Commission de Surveillance du Secteur Financier, and whose operator is based in Luxembourg.

P**PD**

Payment Date.

PPA

Principal Paying Agent. An Agent appointed by the Issuer to process the cash payments to be made by the Issuer (collection of coupon, redemption or other monies) related to a security.

Q**Qualifying Security**

A Qualifying Security is a security that LuxCSD has assessed the security against eligibility criteria and determines that timely and accurate asset servicing can be performed during the life of the security.

T**Terms and Conditions**

The contractual provisions governing the relevant securities set out in (or incorporated into) the global certificate or in the articles of association. Published in a Prospectus for Stand-Alone issues or a Base Prospectus supplemented by Final Terms for issuance under Programme.

T2S (DCA)

TARGET2 payment system operated by the European Central Bank.

This page has intentionally been left blank.

Contact

reachus@luxcsd.com

Published by

LuxCSD

Registered address

LuxCSD S.A.
42 avenue J F Kennedy
L-1855 Luxembourg

Postal address

LuxCSD S.A.
L-2967 Luxembourg

Document number: 6578
